

500ml White BioBoard Takeaway Base BB-LB-500-W

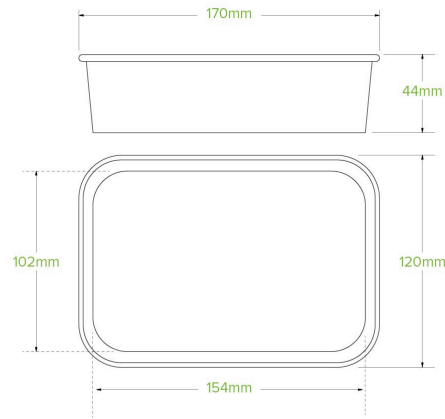

500ml White Rectangular Paper Containers are sustainably sourced and made from FSC™ certified paper board. They are lined with a bioplastic made from plants, not oil. These takeaway containers are perfect for hot and greasy food. Certified industrially compostable.

Carton quantity: 300	Sleeves per carton: 6	Units per sleeve: 50
Carton Size LxWxH (cm): 38x36x44	Carton gross weight (kg): 5.500000	Carton barcode: 19344062067785
Raw Material: Paper - FSC™ Mix certified paper	Lining/coating: Bioplastic - PLA	Window Material: None
Printing Type: Flexo	Inks: Food Contact Safe Inks	Brim fill capacity (ml): 520
Dimensions top LxW (mm): 172x120	Dimensions base LxW (mm): 154x102	Product Depth: 41
Thickness: 350gsm	Use: Hot, Cold, Wet & Dry Products	Manufactured: China
Customise: Print	MOQ custom: 50000	Mould fees: Yes - see custom packaging
Home compostable: No	Industrially compostable: Certified to AS4736 Australian Standards, Certified to EN13432 European Standard	Recyclable: No